



श्री GANESH DECOR

ALL ABOUT ALUMINIUM

SINCE 2010



श्री गणेश डेकोर

ABOUT US

Established in 2010, Shri Ganesh Decor has emerged as a brand leader in India's Aluminium Industry. With its headquarters in Bikaner, India. Shri Ganesh Décor has expanded its area of operation across the country through its venture "SGD Gallery" Shri Ganesh Decor is a legacy brand with a remarkable 15-year history of manufacturing customized window solutions that embody the core tenets of Durability, Precision, Performance, and Innovation.

Headquartered in Bikaner with Pan India Presence in 10+ Cities in association with our partners and fabricators which gives us the ability to mobilize 1 to 1000+ windows to different corners of the country with ease. At present, we provide a host of products and services to construction and building material businesses.

Our SGD Support System, offers a comprehensive after-sales service to our clientele. Our unwavering dedication to craftsmanship and customer satisfaction, we aim to exceed expectations and set new standards of excellence in the industry. We strive to be the preferred choice for clients seeking reliable and bespoke window solutions that stand the test of time.

System windows & doors. Through strong supply-chain management processes namely central and regional warehouses, logistics and after sales support system, we are committed to provide trendsetting services and leave an everlasting imprint in the world of aluminium services.

Our Excellence



Indian Design
International Standards
for Indian Affordability



Capacity to serve from
1 to 1000+ Windows



Customised Engineering
Solutions



EASY ADMINISTRATION

15+ years of experience



After sales Support System



CONDUCT TRAINING
SESSION

Consultation &
Training Facility



PAN India presence



श्री ग्रान्डेक्वे वेक्टर

Touch & Feel Experience Centre

SLIMO SLIDING SERIES



Let's
Open
The **Door**
Of New World

Make your dream abode look more premium by installing slim concealed windows. Designed for bungalows and premium apartments, they come equipped with an integrated "Concealed Locking System" with soft fin wool pile.

It ensures that the windows are interlocked comprehensively, shutting out disturbances like dust, noise, and water, by ensuring good functionality and durability. No fitting is visible from the inside, achieving aesthetics of seamless simplicity.

Crafted and designed in contemporary styles to complement your taste, the slim concealed windows can be the most elegant choice for your home decor. Made keeping the consumer needs in mind, these windows are available in an array of choices to cater to your specific needs.

SLIMO SLIDING SERIES

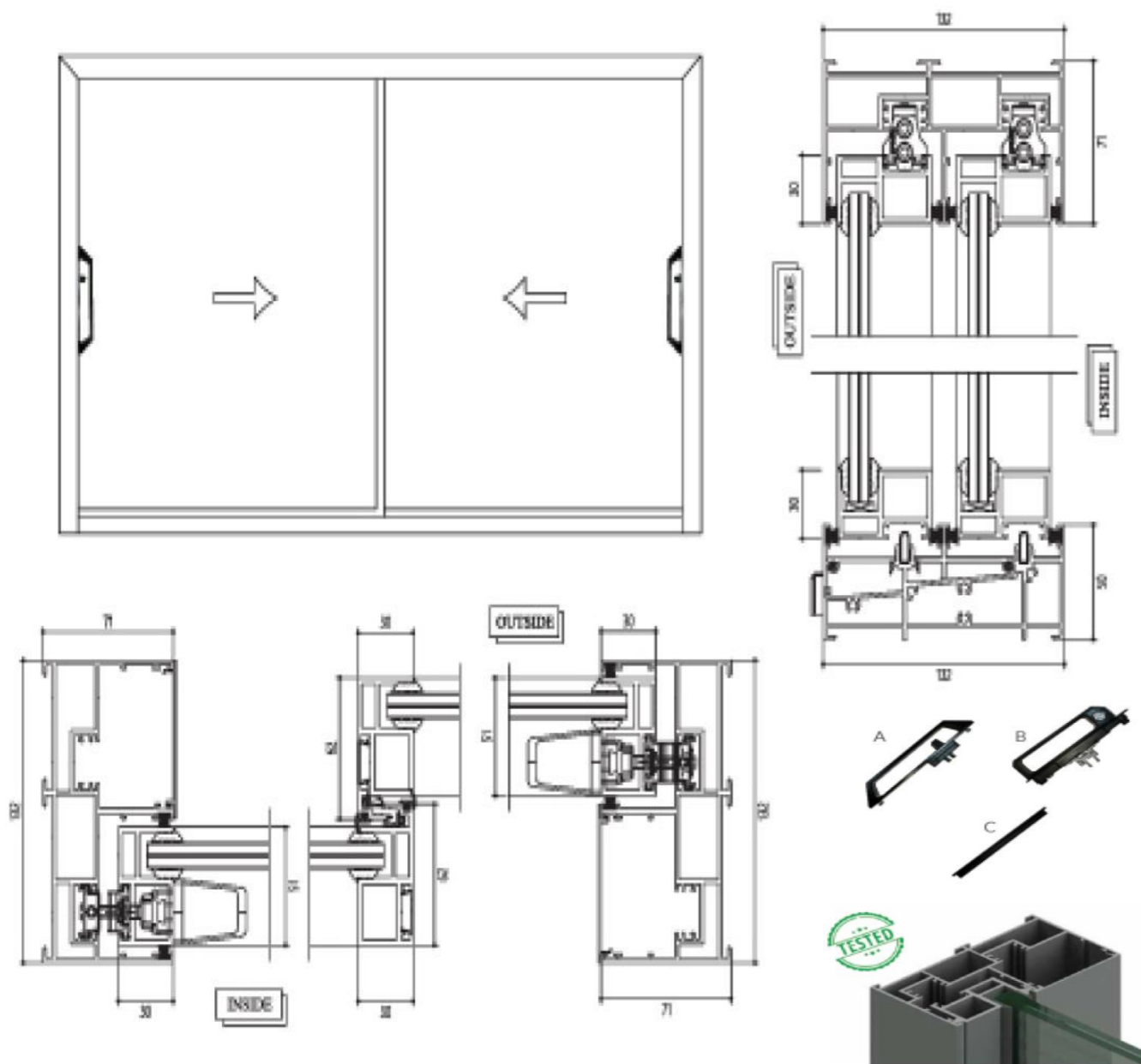

Technical Specification:

- ❖ Available in 2 track and 3 track frames
- ❖ Maximum Shutter Dimensions 1500mm x 3000mm
- ❖ Multiple Locking System
- ❖ Maximum Load Carrying Capacity 300kg/shutter
- ❖ Wind Load Consideration upto 2 Kpa
- ❖ Maximum Glass Thickness 15.52mm
- ❖ Leaf profile width on all sides is extremely narrow
- ❖ Range of height adjustment of the guiding roller is +5mm
- ❖ Hardware Options: (A) Multi point lock pull handle, (B) Multi point lock pull handle & (C) 'L' Multi point pull handle

SLIMO 50mm SLIDING SERIES

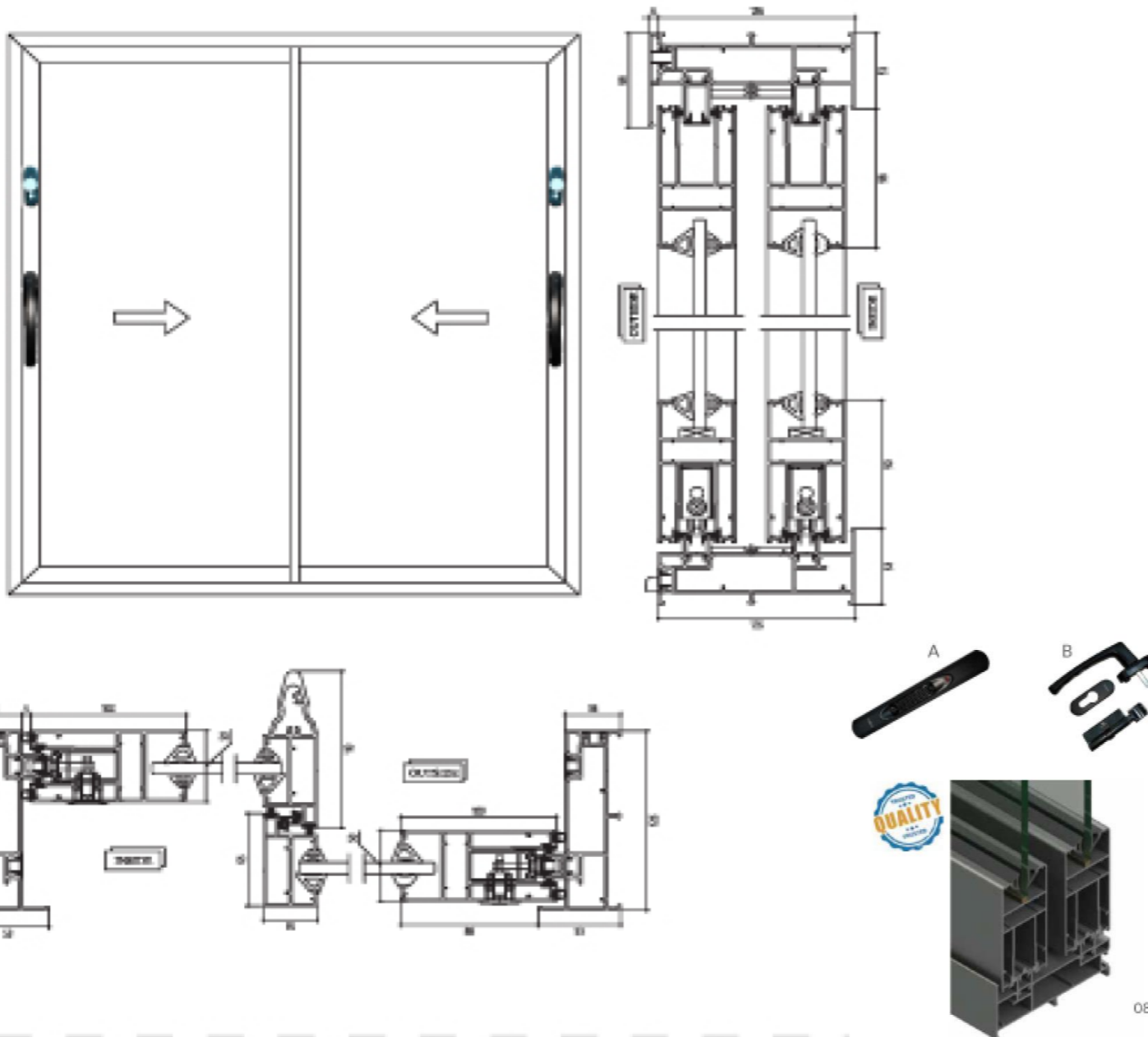

Technical Specification:

- ❖ Available in 2 track and 3 track frames
- ❖ Maximum Shutter Dimensions 1800x3800mm
- ❖ Large Window Openings upto 3800mm in height
- ❖ Glazing Options-5-8mm, 10mm, 20mm, 22mm and 30mm
- ❖ Rollers have Load bearing capacity upto 300 kg per shutter
- ❖ Multiple Point Lock available
- ❖ Well Designed Drainage System (Z" Drainage)
- ❖ Hardware Options: A) Multi point lock B) Multi Point Lock With Cylinder And Handle

SGD SLIM SLIDING SERIES

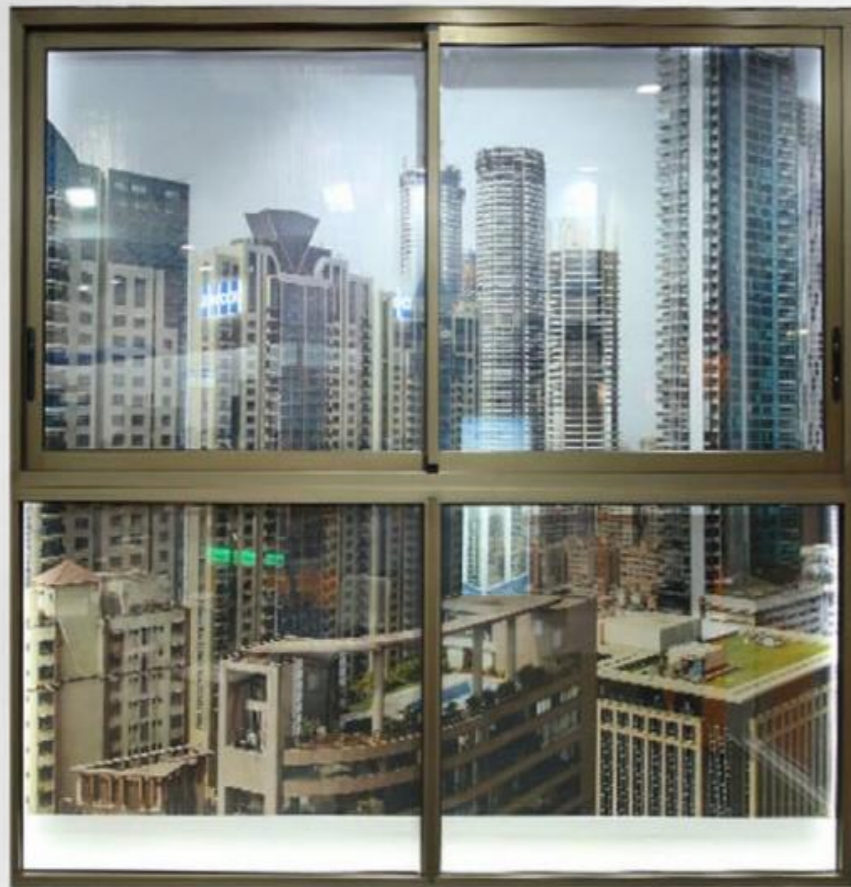

Presenting a new way to enhance the look and feel of your home or office. These sliding windows add both aesthetic value and convenience to your living space. Engineered to slide back and forth, they facilitate more open space and ventilation. They are a great addition for facilitating adequate air circulation in any room.

The exquisitely designed windows add a touch of panache to any space, instantly elevating its look and feel. The multi-point locking systems ensure safety and water-proofing. Their great functionality, durability and easy installation make these windows super user-friendly and feasible.

Crafted to cater to different needs and tastes, these windows are a great choice for small or limited spaces. They make the perfect choice for spaces like cubicles, balconies, interior partitions, and more

40*18 MM SLIDING SYSTEMS

2 TRACK TOP

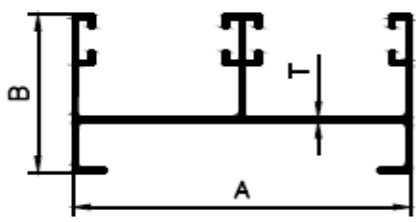

2 TRACK BOTTOM

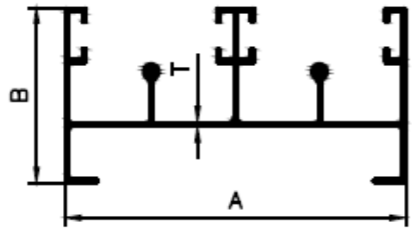

3 TRACK TOP

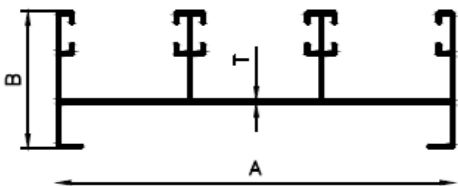

3 TRACK BOTTOM

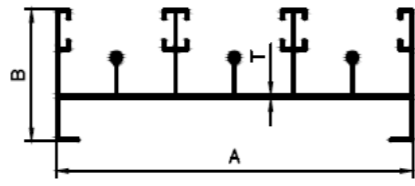

HANDLE

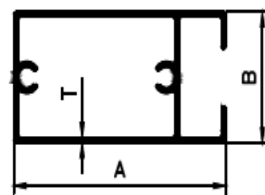

INTER LOCK

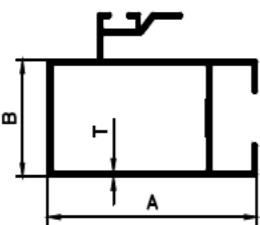

TOP BOTTOM

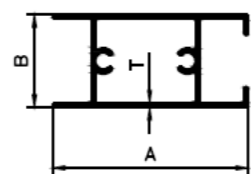

60*18 MM SLIDING SYSTEMS

2 TRACK TOP

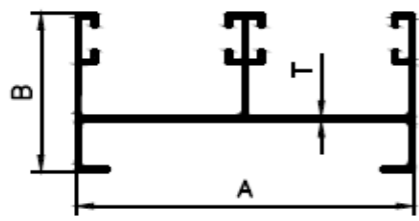

2 TRACK BOTTOM

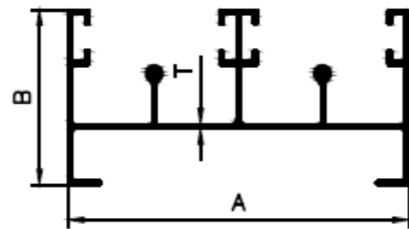

3 TRACK TOP

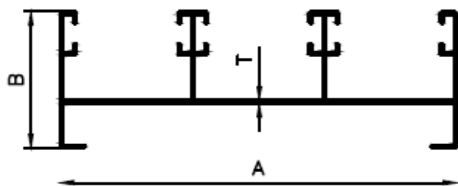

3 TRACK BOTTOM

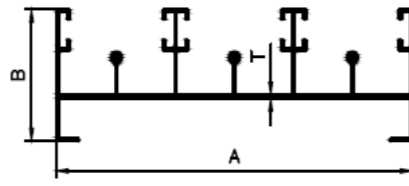

HANDLE

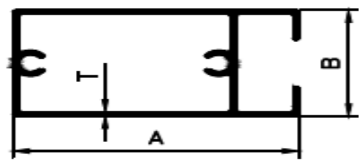

INTER LOCK

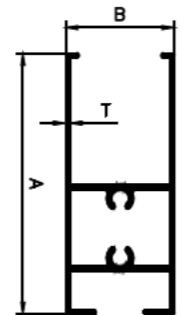
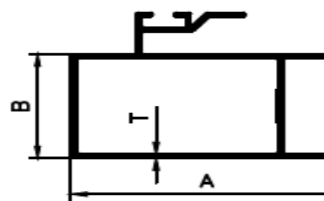

BEARING BOTTOM



60*22 MM DOMAL SLIDING SYSTEMS

2 TRACK

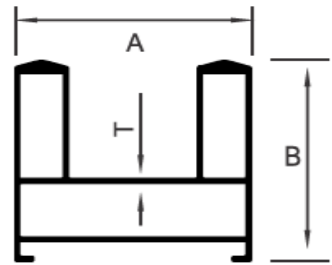

3 TRACK

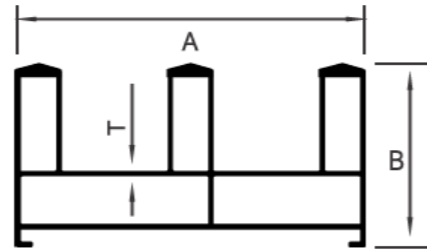

GLASS SHUTTER

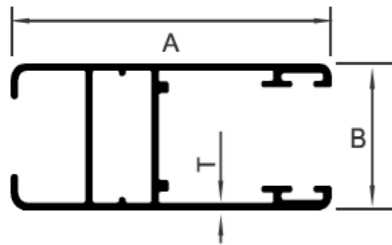

INTERLOCK CLIP

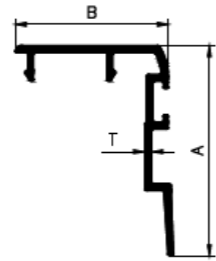

60*25 MM DOMAL SLIDING SYSTEMS

2 TRACK

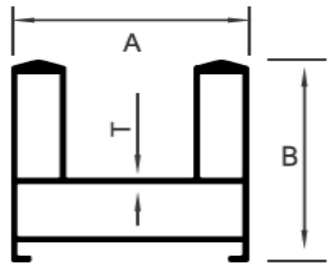

3 TRACK

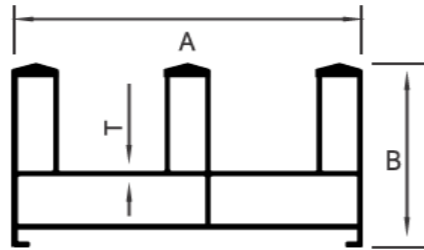

GLASS SHUTTER

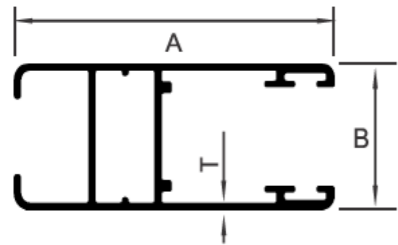

INTERLOCK CLIP

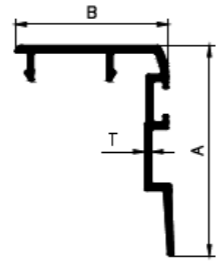

75*27 MM SLIM-LINE SLIDING SYSTEMS

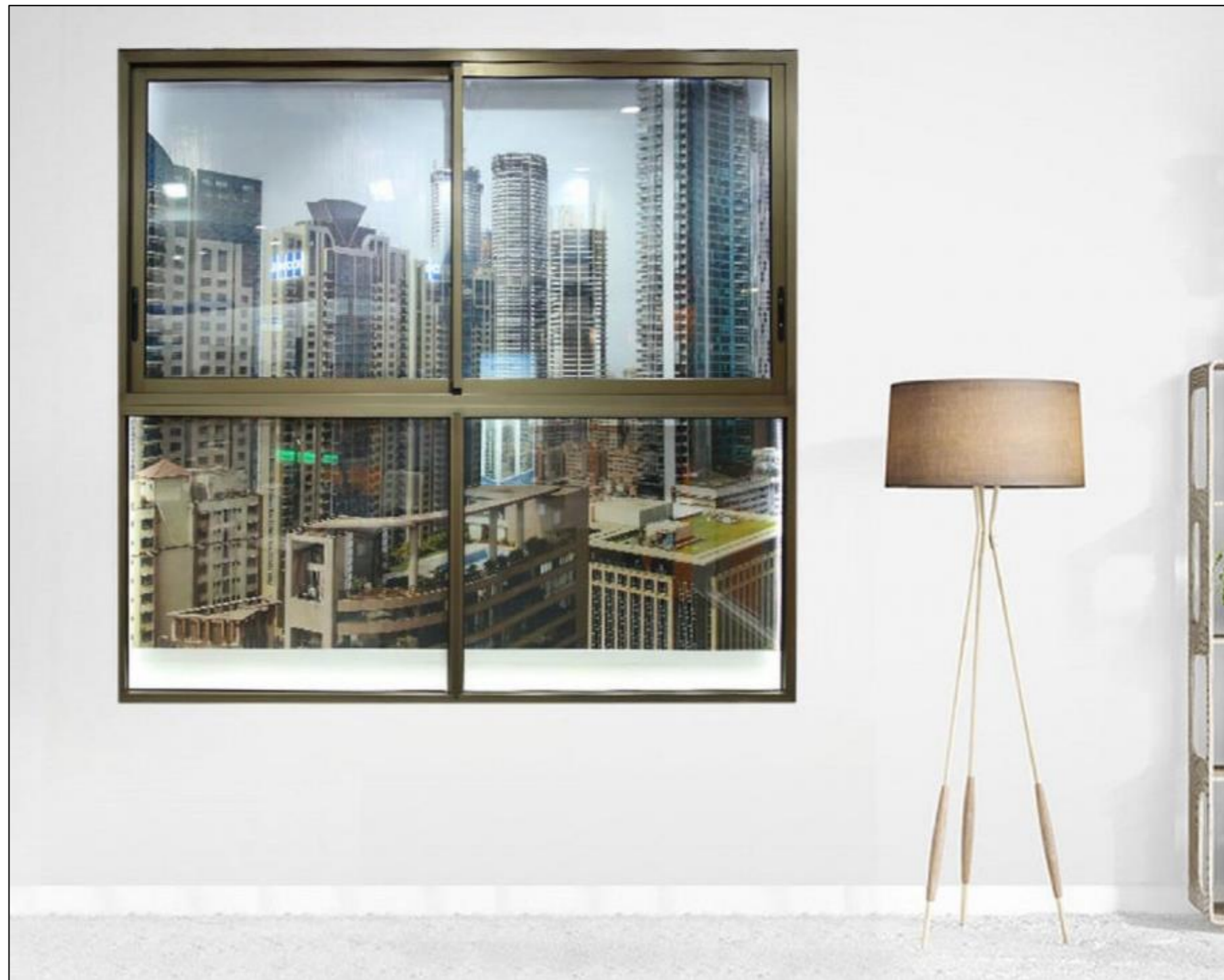
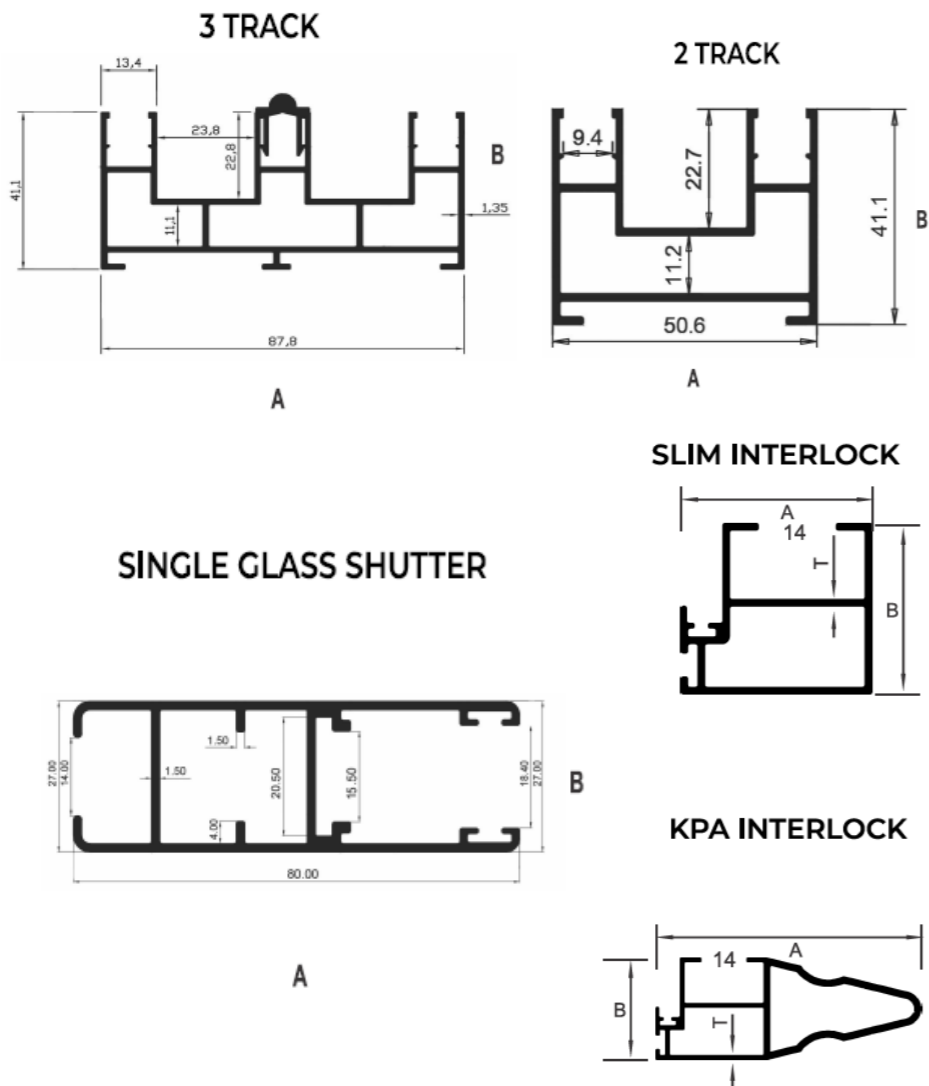

75*27 MM DGU SLIM-LINE SLIDING SYSTEMS

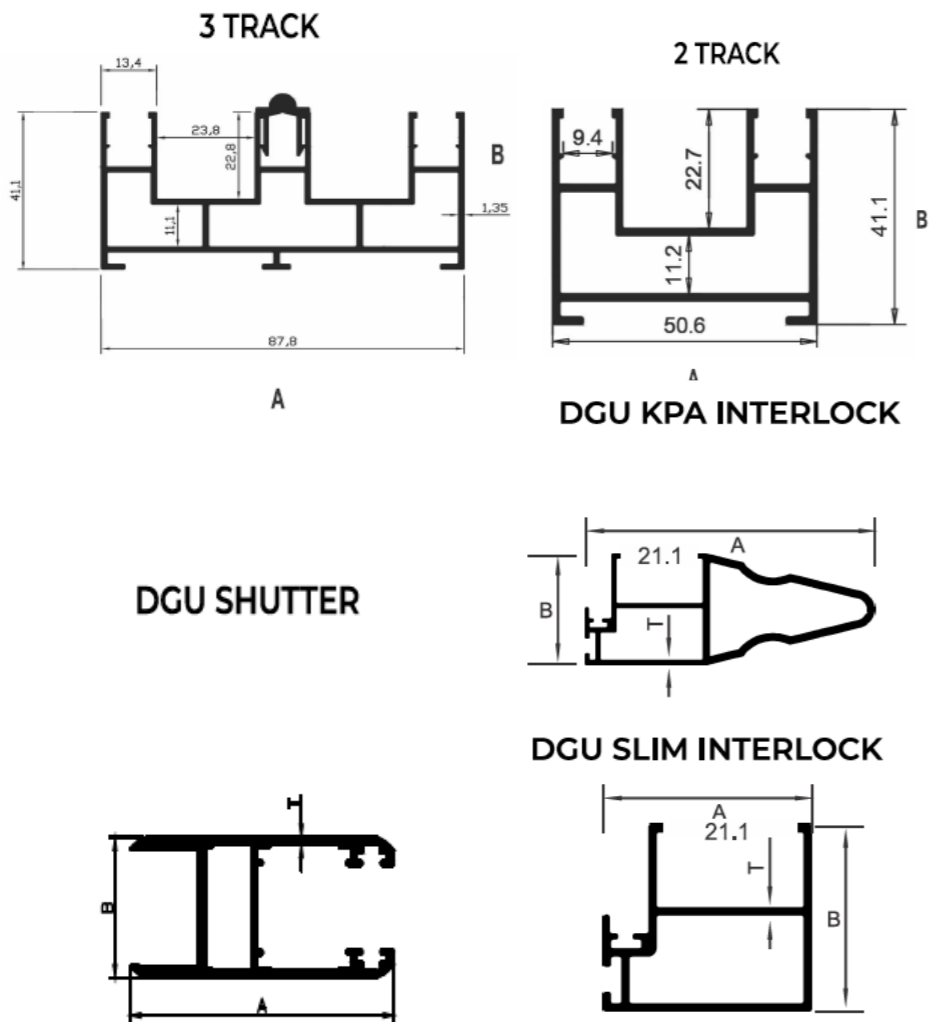



ALUMINIUM RAILINGS

श्री गणेश वेक्टर



Our company specializes in designing and constructing high-quality Aluminum Glass Railings. Our railings are customized to fit each customer's specifications and needs, allowing them to have a unique fence that perfectly suits their space.



ABOUT ALUMINIUM RAILINGS

श्री खण्डेकर वेक्टर



SGD Aluminium Railing System, a sleek and stylish solution for enhancing the safety and aesthetics of your space. Crafted with precision and built to last, this railing system is designed to elevate the look of any residential or commercial property. SGD Aluminium Railing System offers a perfect combination of durability, versatility, and contemporary design. Made from high-quality aluminium, it provides exceptional strength and resistance to corrosion, ensuring long-lasting performance even in challenging outdoor environments. With its clean lines and modern appeal, the SGD Aluminium Railing System seamlessly integrates into any architectural style. Whether you're looking to enhance the beauty of your home, office, or public space, this railing system offers a timeless elegance that complements any setting. Installation of the SGD Aluminium Railing System is quick and hassle-free, thanks to its innovative modular design. The system comes with pre-fabricated components that can be easily assembled, allowing for efficient installation without compromising on quality.



ALUMINIUM RAILING -TOP

श्री खण्डेख वेक्टर



PRODUCT CODE: #8501 - 2305

Width - 40MM
Height - 40MM



PRODUCT CODE: #8502 - 2405

Width - 50MM
Height - 50MM



PRODUCT CODE: #8503 - 2405

Width - 50MM ROUND
Height - 50MM ROUND



ALUMINIUM RAILING -TOP

श्री खान्दाख वेक्टर



PRODUCT CODE: #8506 - 2705

Width - RACTANGULAR 60 MM
Height - RACTANGULAR 60 MM



PRODUCT CODE: #8504 - 2405

Width - 40MM ROUND
Height - 40MM ROUND



PRODUCT CODE: #8616 - 2705

Width - 40 MM
Height - 50 MM



ALUMINIUM RAILING -TOP

श्री खान्दाख वेक्टर



PRODUCT CODE: #8510 - 2605

Width - 70MM
Height - 70MM



PRODUCT CODE: #8512 - 2705

Width - INCLINE 75 MM
Height - INCLINE 50MM



PRODUCT CODE: #8508 - 2605

Width - 55MM
Height - 30MM



ALUMINIUM RAILING -BOTTOM



PRODUCT CODE: #9501 - 2501

Width - 67 MM
Height - 97 MM



PRODUCT CODE: #9507 - 4001

Width - 56 MM
Height - 71 MM



PRODUCT CODE: #9509 - 2801

Width - 45 MM
Height - 60 MM

ALUMINIUM IN PARTITION

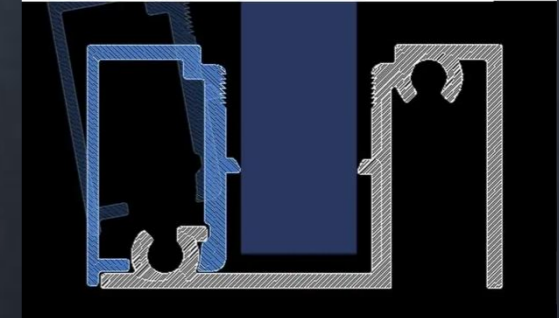

We also make Aluminium partition by using aluminium alloy frame. The whole glass (monolayer or double layer) is installed inside the aluminium frame, forming the effect of the integral partition wall. It is widely used in offices, car exhibition halls, home decoration or wherever needed. The complete production and installation of sections, glazing, indoor, outdoor and customise partition in multiple aluminium sections done by us



BENEFITS OF ALUMINIUM ANODISING

- 1. Corrosion Resistance:** The anodized layer that is formed on the surface of the aluminum is highly resistant to corrosion, making it suitable for use in aggressive environments.
- 2. Durability:** Anodized aluminum is more durable than other surface finishes. The anodized layer is integrated with the underlying aluminum, so it cannot peel or flake off.
- 3. Aesthetic Appeal:** Anodized aluminum offers a wide range of colors and finishes to give it an attractive and decorative appearance. It can also be polished to a mirror finish.
- 4. Low Maintenance:** Anodized aluminum requires minimal maintenance. It does not need to be repainted or recoated, which saves time and money over the long-term.
- 5. Eco-Friendly:** The anodizing process is environmentally friendly, as it uses non-toxic and biodegradable chemicals, and produces no harmful by-products.
- 6. Improved Strength:** Anodized aluminum has increased resistance to wear and tear, making it stronger and more durable.
- 7. Thermal Properties:** Anodized aluminum has excellent thermal properties, making it useful in applications that require good heat dissipation.



WHAT IS POWDER COATING?

Powder coating is a dry finishing process that involves applying a fine powder to a surface using an electrostatic spray gun. The powder is made up of a mixture of resin, pigment, and other additives, which are then heated and cured to create a hard, durable finish.

How does Powder Coating Work?

The powder coating process involves a series of steps to ensure a high-quality finish. First, the surface to be coated is cleaned and pre-treated to remove any debris or contaminants that could affect adhesion. Next, the powder is applied using an electrostatic spray gun, which gives the powder a positive charge and causes it to stick to the surface.

Once the powder is applied, the coated surface is heated to a high temperature, which causes the powder to melt and flow together, forming a smooth, even finish. This heating process, known as curing, also activates the cross-linking process, which bonds the powder to the surface and creates its durable properties.

Advantages of Powder Coating

- **Durability:** Powder coated surfaces are highly resistant to chipping, scratching, and fading, making them ideal for high-traffic areas.
- **Sustainability:** Powder coating is an environmentally friendly option, as it produces less waste and has fewer harmful emissions than traditional liquid coatings.
- **Versatility:** Powder coating can be used on a wide range of surfaces and can be customised to create a variety of finishes, from matte to glossy.
- **Cost-effective:** While the upfront cost of powder coating may be slightly higher than traditional liquid coatings, its durability and long-lasting finish can save you money in the long run by reducing the need for frequent touch-ups and repairs.



MEET OUR DIRECTORS

Ganesh B. Suthar - MD

Vijay B. Suthar : Director

Pankaj B. Suthar : Director

Our company has a rich history that dates back to the 1980s when we began as traditional stone carvers. In the mid-90s, we expanded our services to include metal fabrication and became a turnkey contractor for both interior and exterior projects. In 2012, we established our own facility in Nokha for powder coating, and anodizing. Today, we are proud to be India's largest door and windows manufacturer with in-house facilities of aluminum sections, and we supply and install the products across the globe.



श्री गणेशे डेकोर

SHRI GANESH DECOR

Office Address

B.L Market, Floor No. Ground, First, Second Near Navli Gate Nokha- 334803

Factory Address

No.42 RIICO Industrial Area Nokha- 334803

No.420 Gopal Charan Ind. Zon Ahamedabad

Contact :- 7506523396

www.shriganeshdecor.com